

HY0020

Bluetooth[®] low energy module with Slot Antenna Built into Shielded Package

- The Bluetooth[®] word mark and logos are registered trademarks owned by Bluetooth SIG, Inc. and any use of such marks by FDK CORPORATION is under license. Other trademarks and trade names are those of their respective owners.
- Arm and Cortex are registered trademarks of Arm Limited (or its subsidiaries) in the US and/or elsewhere.
- FDK Corporation is granted a license to use Slot Antenna on Shielded Package Technology patented by Toshiba Corporation.

Version	Date	Description
1.0	Apr.19, 2024	First edition issued

1 Product Overview and Features

1.1 Product Overview

Bluetooth® low energy module with "Slot Antenna on Shielded Package Technology" is a 2.4GHz wireless communication (Bluetooth®) blank radio module with Nordic Semiconductor nRF52832. A basic protocol stack can be installed via Flash mounted on the IC, and various applications can be developed with this module alone. In addition, the module has acquired various radio and SIG certifications on its own, which simplifies various certifications for customers.

1.2 Features

- Slot Antenna on Shielded Package
 - Ultra-compact module with antenna pattern designed on the shield. Size: 3.5 x 10 x 1 mm
 - Large keep out areas are not required. World's smallest occupied area for printed circuit boards. (As of September 1, 2023. According to our research.)
- Bluetooth® ver.5.4 low energy conformity
 - Low energy 2 Mbps
 - Output power: +4 dBm to -20 dBm (4 dB step)
 - Sensitivity: -94 dBm (1 Mbps)
- Integrated Processor System
 - Arm® Cortex®-M4 32-bit processor with FPU, 64MHz
 - Flash 512KB
 - Soft Device (protocol stack) is offered
 - Serial wire debug (SWD)
- RAM 64KB
- Configurable 16 pin GPIO
 - UART, SPI, TWI (I2C), QDEC
 - Wake-up function for sleep and deep sleep
 - 4-channel PWM output for LED and buzzer control
 - PDM input for microphone
 - 12-bit, 200 ksps ADC - 6 configurable channels
- Flexible power management, fully automatic LDO and DC/DC regulator system
 - 1.7 V–3.6 V supply voltage range
 - Low power mode
 - ◇ 1.9 μA at 3 V in System ON mode, no RAM retention, wake on RTC
- Weight: 0.08 g (Typ.)

2 Outline

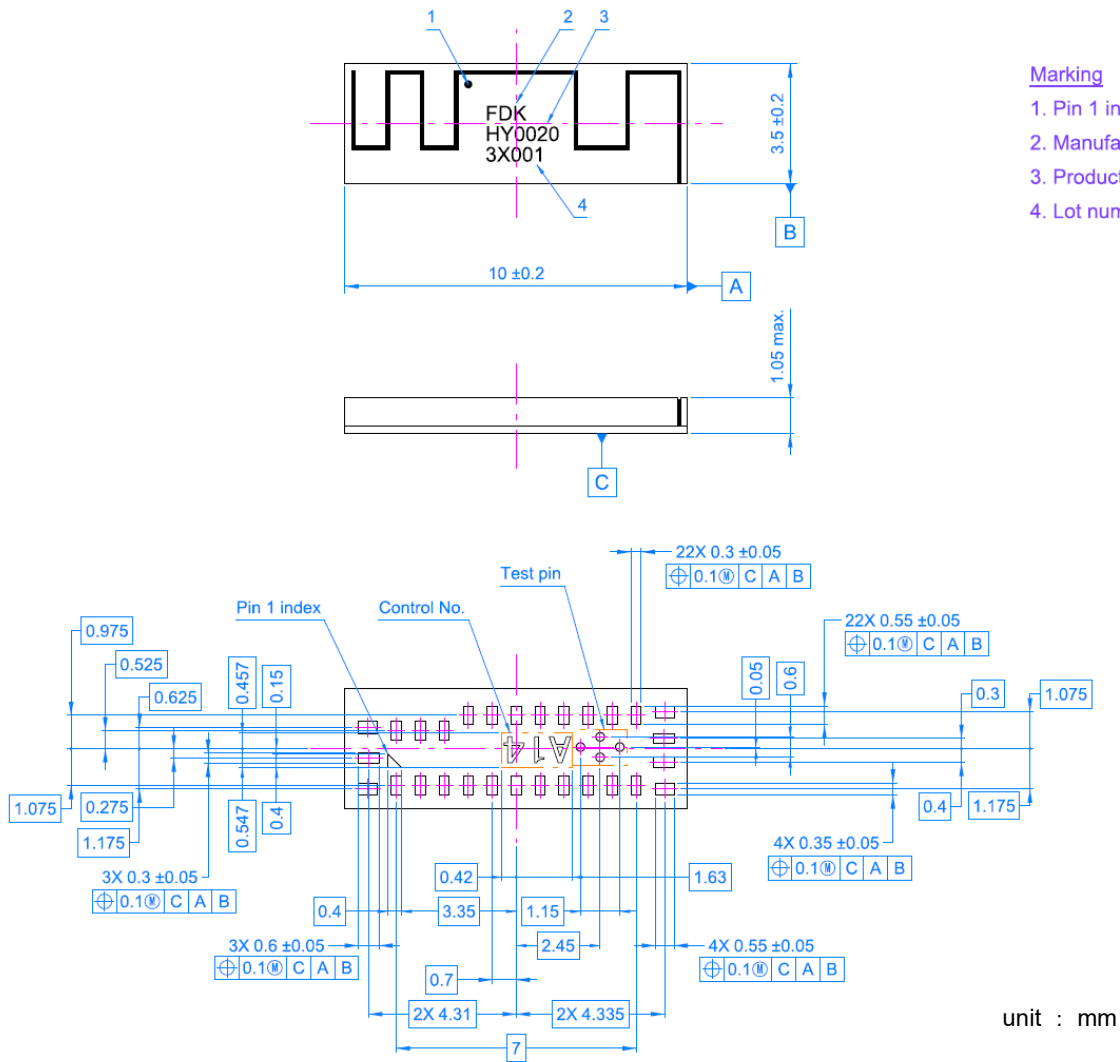

Figure 2-1 Outline

3 Block Diagram

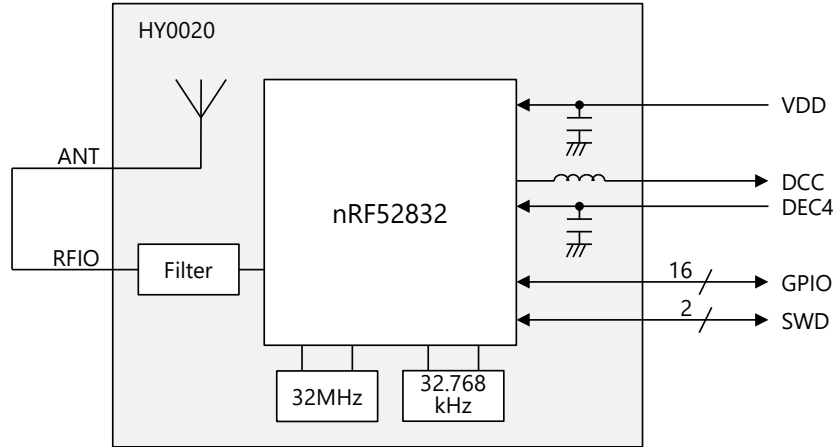

Figure 3-1 Block Diagram

4 Pin Definitions

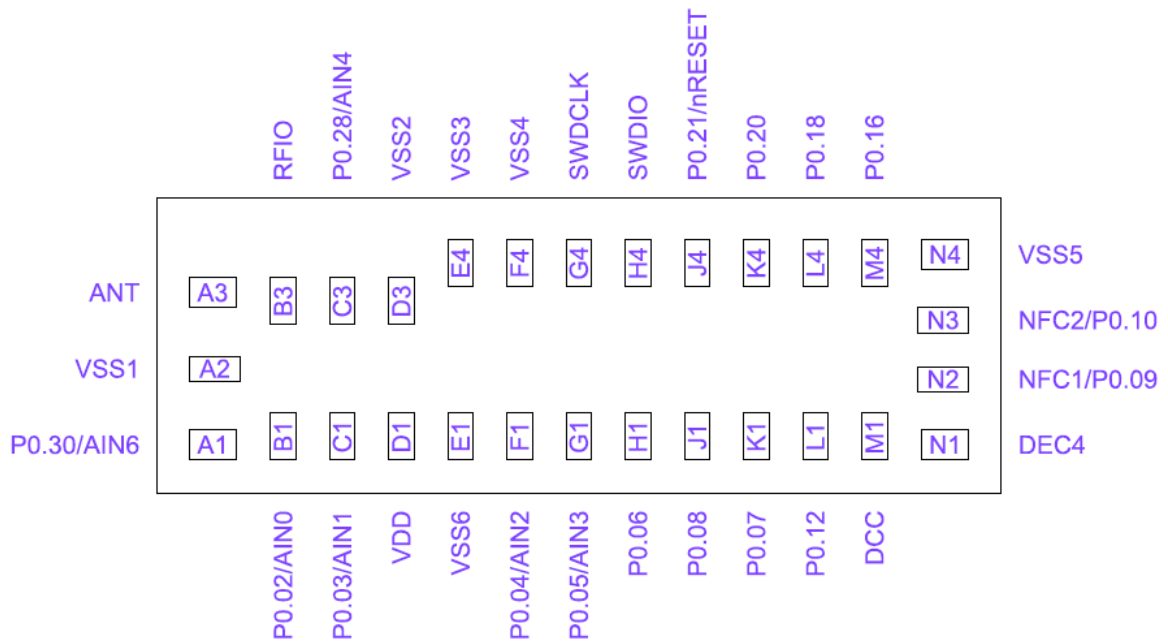

Figure 4-1 Pinout Diagram (Bottom View)

Table 4-1 Pinout

Pin	Name	Type	Description
J4	P0.21/nRESET	Digital I/O	General purpose I/O Configurable as pin reset
B3	RFIO		RF I/O pin. It should be connected to Pin A3.
A3	ANT		Internal antenna I/O pin. It should be connected to Pin B3. This product has a built-in 50 Ω matching circuit and antenna, so no additional external elements are required.
K4 L4 M4 L1 J1 K1 H1	P0.20 P0.18 P0.16 P0.12 P0.08 P0.07 P0.06	Digital I/O	General purpose I/O
A1 C3 G1 F1 C1 B1	P0.30/AIN6 P0.28/AIN4 P0.05/AIN3 P0.04/AIN2 P0.03/AIN1 P0.02/AIN0	Digital I/O Analog input	General purpose I/O SAADC/COMP/LPCOMP input
N3 N2	NFC2/P0.10 NFC1/P0.09	NFC input Digital I/O	NFC antenna connection General purpose I/O
G4	SWDCLK	Digital input	Serial wire debug clock input for debug and programming
H4	SWDIO	Digital I/O	Serial wire debug I/O for debug and programming
D1	VDD	Power	Power supply
M1	DCC	Power	DC/DC converter output
N1	DEC4	Power	1.3 V regulator supply decoupling. Input from DC/DC converter. Output from 1.3 V LDO.
E1 N4 F4 E4 D3 A2	VSS6 VSS5 VSS4 VSS3 VSS2 VSS1	Power	Ground

5 Reference Circuits

Connect the RFIO and ANT terminals with the shortest possible length of 50Ω transmission line. Connect the DCC and DEC4 pins as shown in Figure 5-1 when using the built-in LDO and Figure 5-2 when using the built-in DC/DC converter. Regardless of the circuit connection status, a register setting by software is required.

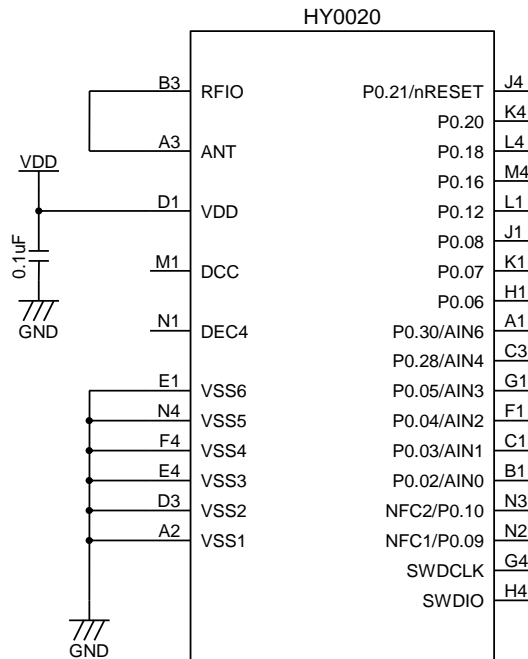

Figure 5-1 Built-in LDO regulator circuit example

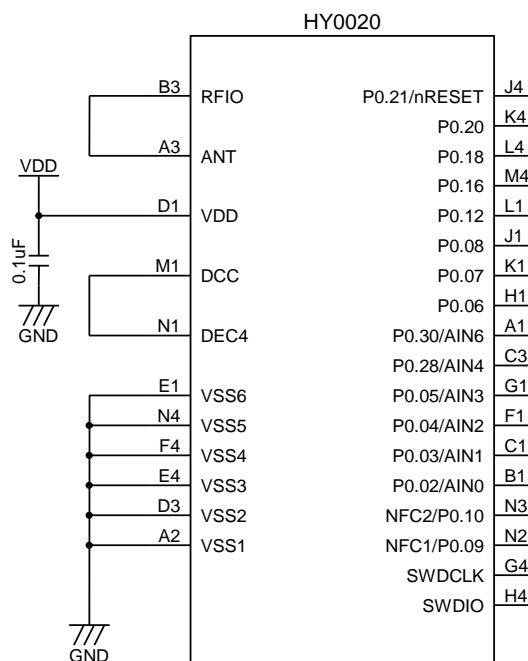

Figure 5-2 Built-in DC/DC converter circuit example

6 Electrical specification

6.1 Absolute maximum ratings

Absolute maximum ratings are standards that must not be exceeded even momentarily. Exceeding the absolute maximum ratings may cause deterioration or damage to internal components and may also destroy, damage, or degrade external circuits other than the module. The application equipment should be designed to ensure that the absolute maximum ratings are not exceeded under any operating conditions.

Table 6-1 Absolute maximum ratings

Parameter	Symbol	Condition	Min.	Max.	Unit
Supply voltage	VDD		-0.3	+3.9	V
I/O pin voltage	V _{I/O}	VDD ≤ 3.6V	-0.3	VDD + 0.3	V
		VDD > 3.6V	-0.3	+3.9	V
RF input level	RFIO		-	+10	dBm
Storage temperature	Tstg		-40	+85	°C

*1. VSS = GND = 0V

6.2 Recommended operating conditions

Recommended operating conditions refer to the conditions under which this product operates normally with a certain level of quality. If any one of the operating conditions is not met, the product may malfunction. Therefore, please ensure design of the applied equipment is such that the operating conditions of this product do not exceed the specified range of the operating conditions.

Table 6-2 Recommended operating conditions

Parameter	Symbol	Condition	Min.	Typ.	Max.	Unit
Supply voltage	VDD		1.7	3.0	+3.6	V
Supply rise time	t _{R VDD}	0V to 1.7V	-	-	60	ms
Operating temperature	Ta		-40	+25	+85	°C

*1. VSS = GND = 0V

*2. Be sure to connect a bypass capacitor near the module for use.

*3. The on-chip power-on reset circuitry may not function properly for rise times longer than the specified maximum.

*4. After power off, it must start up from below 0.3V.

6.3 DC Specifications

The DC electrical characteristics at ambient operating temperature (T_a) = 25°C, VDD = 3.0 V, and DC/DC = ON are shown in Table 6-3.

Table 6-3 DC Specifications

Parameter	Symbol	Condition	Min.	Typ.	Max.	Unit
Input high voltage	V_{IH}		$0.7 \times V_{DD}$	-	-	V
Input low voltage	V_{IL}		-	-	$0.3 \times V_{DD}$	V
Output high voltage	V_{OH}	$I_{OH} = 5\text{mA}$	$V_{DD} - 0.4$	-	-	V
Output low voltage	V_{OL}	$I_{OL} = 5\text{mA}$	-	-	0.4	V
Pull-up resistance	R_{PU}		11	13	16	kΩ
Pull-down resistance	R_{PD}		11	13	16	kΩ
TX only run current	I_{TX1}	DC/DC, $P_{RF} = +4\text{dBm}$	-	7.5	-	mA
	I_{TX2}	DC/DC, $P_{RF} = 0\text{dBm}$	-	5.3	-	mA
	I_{TX3}	LDO, $P_{RF} = +4\text{dBm}$	-	16.6	-	mA
	I_{TX4}	LDO, $P_{RF} = 0\text{dBm}$	-	11.6	-	mA
RX only run current	I_{RX1}	DC/DC, 1Mbps BLE	-	5.4	-	mA
	I_{RX2}	LDO, 1Mbps BLE	-	11.7	-	mA
Sleep current	I_{sleep}	System Off		0.3		uA

*1. VSS = GND = 0V

6.4 RF Specifications

The RF electrical characteristics at ambient operating temperature (T_a) = 25°C, VDD = 3.0 V, and DC/DC = ON are shown in Table 6-4.

Table 6-4 RF Specifications

Parameter	Symbol	Condition	Min.	Typ.	Max.	Unit
Operating frequencies	f_{OP}		2402		2480	MHz
Frequency deviation	$f_{\Delta 1M}$	BLE 1Mbps	-	±250	-	kHz
	$f_{\Delta 2M}$	BLE 2Mbps	-	±500	-	kHz
Maximum output power	P_{RF}		-	4	6	dBm
RF power control range	P_{RFC}		-	24	-	dB
1st Adjacent Channel Transmit Power 2MHz	P_{RF1}	2Mbps BLE mode	-	-20	-	dBc
2nd Adjacent Channel Transmit Power 4MHz	P_{RF2}	2Mbps BLE mode	-	-50	-	dBc
Receiver sensitivity 1Mbps BLE ideal transmitter	$P_{SENS_1M_DCDC}$	DC/DC	-	-93.5	-	dBm
	$P_{SENS_1M_LDO}$	LDO		-94.5		dBm
Receiver sensitivity 2Mbps BLE ideal transmitter	$P_{SENS_2M_DCDC}$	DC/DC	-	-90	-	dBm
	$P_{SENS_2M_LDO}$	LDO		-91		dBm

*1. VSS = GND = 0V

7 Packaging

7.1 Packaging specifications

(1) Packaging materials

Table 7-1 Packaging materials

Name	Materials	Appearance	Note
Embossed carrier tape	Polystyrene	Figure 7-5	Conductivity
Cover tape	Polyethylene terephthalate Polyethylene Polystyrene		Antistatic
Reel	Polystyrene	Figure 7-6	Conductivity
Aluminum moisture barrier bag	Polyester		Antistatic
Desiccant	Silica gel		
Humidity indicator card			
Label			
Inner carton	Corrugated paper	Figure 7-1	
Outer carton	Corrugated paper	Figure 7-1	

(2) Packaging style

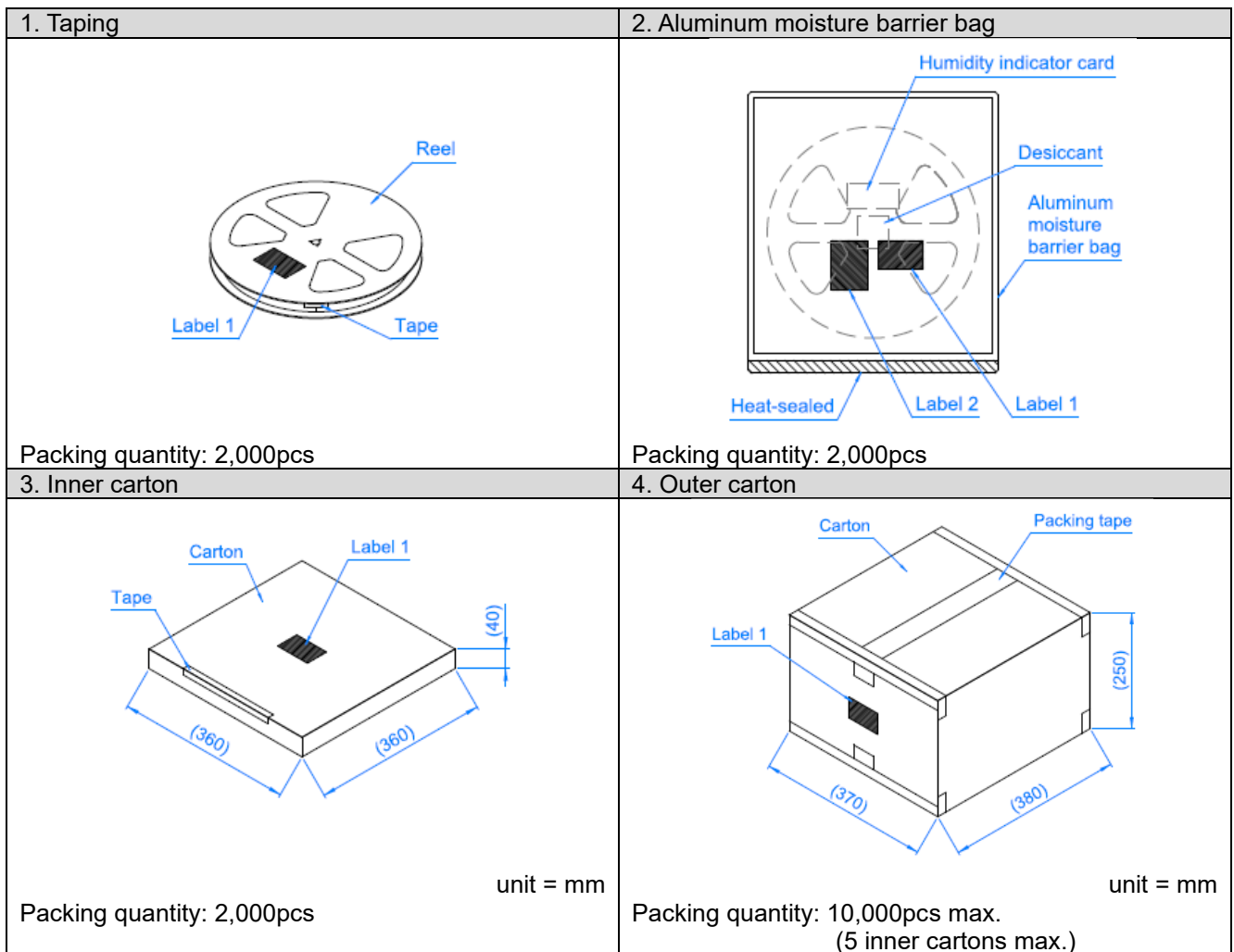
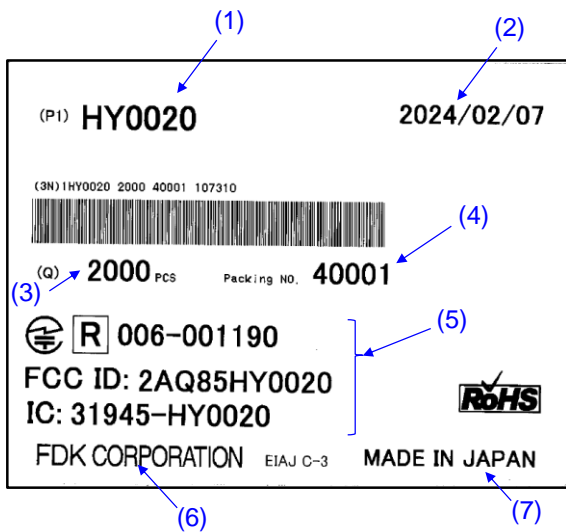

Figure 7-1 Packaging style

(3) Label



(1)	Product's number	HY0020
(2)	Packing date (yyyy/mm/dd)	2024/02/07
(3)	Quantity	2,000pcs
(4)	Packing NO.	40001
(5)	Certification ID Japan: USA (FCC): Canada (ISED):	006-001190 2AQ85HY0020 31945-HY0020
(6)	Manufacturer	FDK CORPORATION
(7)	Country of origin	MADE IN JAPAN

Figure 7-2 Label 1

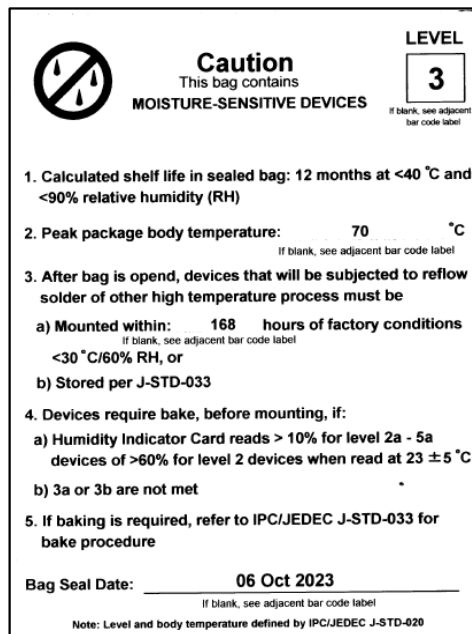

Figure 7-3 Label 2

7.2 Tape specifications

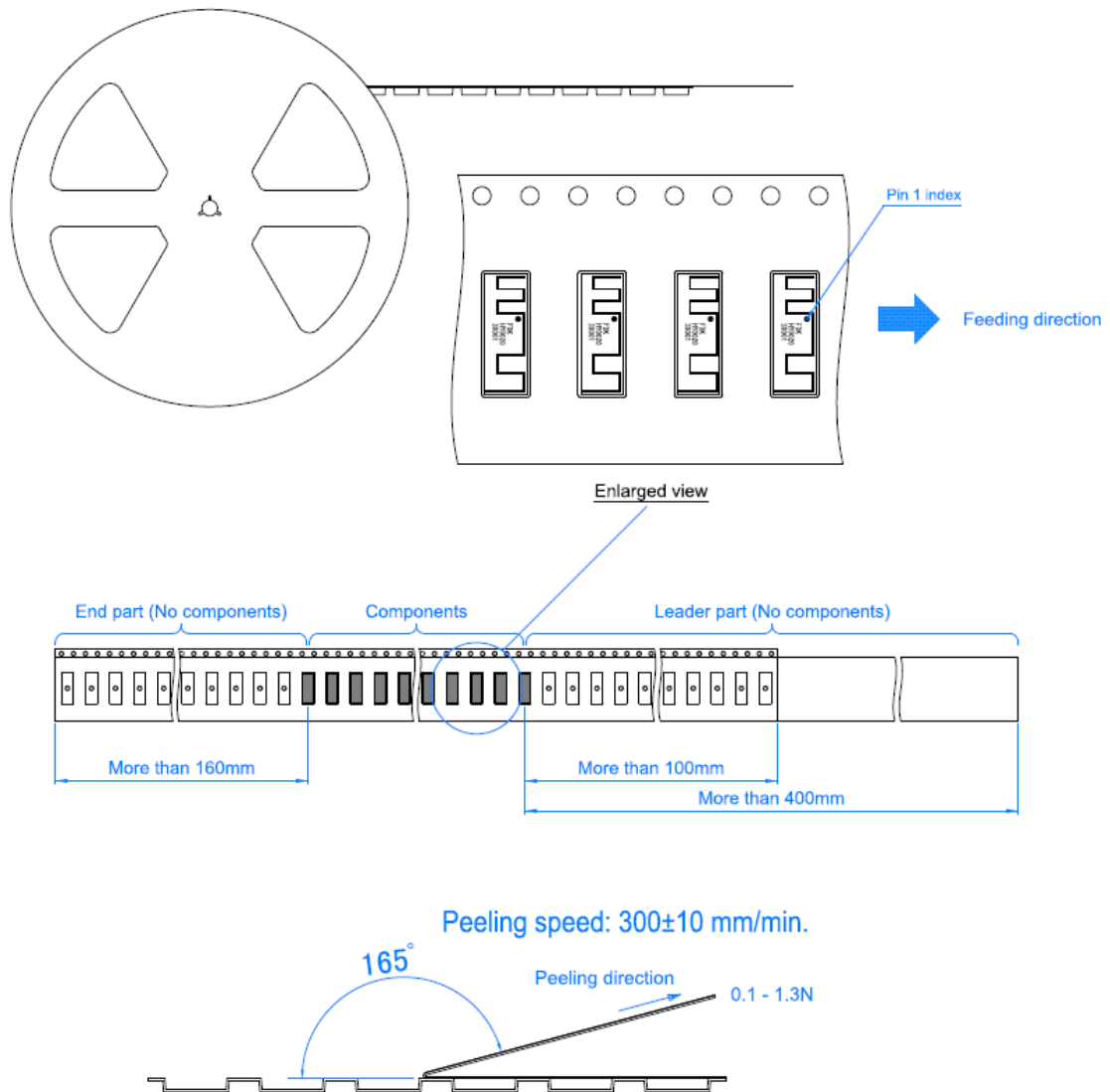

Figure 7-4 Tape specifications

7.3 Dimensions of Embossed carrier tape

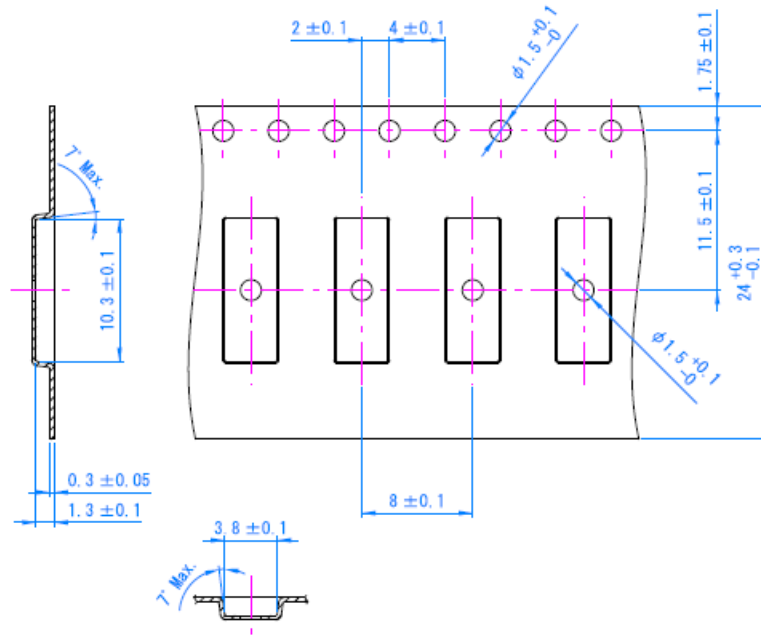

Figure 7-5 Embossed carrier tape dimensions

7.4 Dimensions of Reel

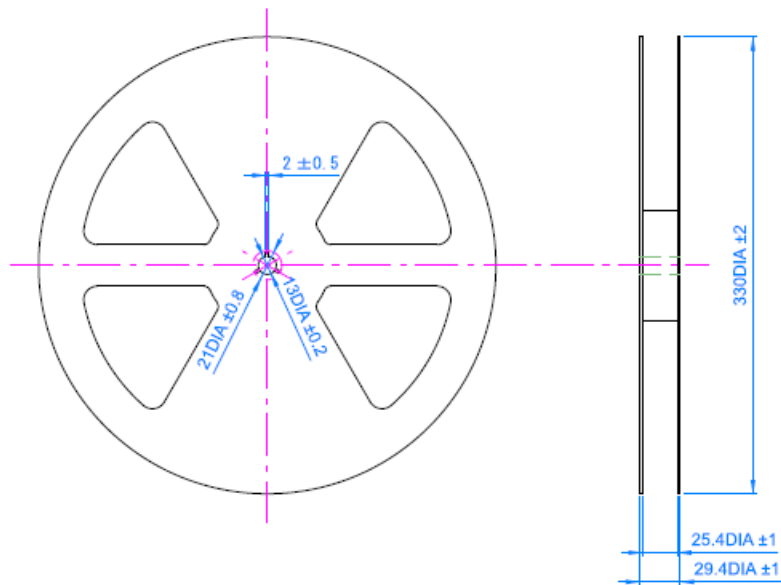

Figure 7-6 Reel dimensions

8 Certification/Qualification information

8.1 Radio Certification

8.1.1 Japan

This product has obtained construction design certification as a radio station for low-power data communication system based on the Radio Law.



8.1.2 USA (FCC)

8.1.2.1 FCC Warning

15.19 Statement

This device complies with part 15 of the FCC Rules. Operation is subject to the following two conditions:

- (1) This device may not cause harmful interference, and
- (2) this device must accept any interference received, including interference that may cause undesired operation.

15.21 Information to user

Warning: Changes or modifications not expressly approved by the party responsible for compliance could void the user's authority to operate the equipment.

The Integrator will be responsible to satisfy SAR/ RF Exposure requirements, when the module integrated into the host device.

8.1.2.2 Limit module procedures

Not applicable

8.1.2.3 Trace antenna designs

Not applicable

8.1.2.4 RF Exposure compliance statement

This equipment complies with FCC radiation exposure limits set forth for an uncontrolled environment and meets the FCC radio frequency (RF) Exposure Guidelines. This equipment should be installed and operated keeping the radiator at least 20cm or more away from person's body.

8.1.2.5 Labeling instruction for Host product integrator

The end product must carry a physical label or shall use e-labeling followed KDB784748D01 and KDB 784748 stating "Contains Transmitter Module FCC ID: 2AQ85HY0020

8.1.2.6 Additional testing, Part 15 Subpart B disclaimer

The modular transmitter is only FCC authorized for the specific rule parts (FCC Part 15.247) listed on the grant, and that the host product manufacturer is responsible for compliance to any other FCC rules that apply to the host not covered by the modular transmitter grant of certification. The final host product still requires Part 15 Subpart B compliance testing with the modular transmitter installed when contains digital circuitry.

8.1.2.7 FCC Statement

(OEM) Integrator has to assure compliance of the entire end-product incl. the integrated RF Module. For 15 B (§15.107 and if applicable §15.109) compliance, the host manufacturer is required to show compliance with 15 while the module is installed and operating.

Furthermore the module should be transmitting and the evaluation should confirm that the module's intentional emissions (15C) are compliant (fundamental / out-of-band). Finally the integrator has to apply the appropriate equipment authorization (e.g. Verification) for the new host device per definition in §15.101.

Integrator is reminded to assure that these installation instructions will not be made available to the end-user of the final host device.

The final host device, into which this RF Module is integrated" has to be labeled with an auxiliary label stating the FCC ID of the RF Module, such as "Contains FCC ID: 2AQ85HY0020

"Changes or modifications to this unit not expressly approved by the party responsible for compliance could void the user's authority to operate the equipment."

The Integrator will be responsible to satisfy SAR/ RF Exposure requirements, when the module integrated into the host device.

8.1.2.8 Module statement

The single-modular transmitter is a self-contained, physically delineated, component for which compliance can be demonstrated independent of the host operating conditions, and which complies with all eight requirements of § 15.212(a)(1) as summarized below.

- 1) The radio elements have the radio frequency circuitry shielded.
- 2) The module has buffered modulation/data inputs to ensure that the device will comply with Part 15 requirements with any type of input signal.
- 3) The module contains power supply regulation on the module.
- 4) The module contains a permanently attached antenna.
- 5) The module demonstrates compliance in a stand-alone configuration.
- 6) The device is too small and therefore the FCC ID is in the manual in accordance with 2.925(f). Doing this complies with the labeling requirements in 15.212.
- 7) The module complies with all specific rules applicable to the transmitter, including all the conditions provided in the integration instructions by the grantee.
- 8) The module complies with RF exposure requirements.

8.1.3 Canada (ISED)

8.1.3.1 ISED Statement

The final host device, into which this RF Module is integrated" has to be labeled with an auxiliary label stating the IC of the RF Module, such as" Contains transmitter module IC: 31945-HY0020

Le périphérique hôte final, dans lequel ce module RF est intégré "doit être étiqueté avec une étiquette auxiliaire indiquant le CI du module RF, tel que" Contient le module émetteur IC: 31945-HY0020

This device contains licence-exempt transmitter(s)/receiver(s) that comply with Innovation, Science and Economic Development Canada's licence-exempt RSS(s). Operation is subject to the following two conditions:

- (1) This device may not cause interference.
- (2) This device must accept any interference, including interference that may cause undesired operation of the device.

L'émetteur/récepteur exempt de licence contenu dans le présent appareil est conforme aux CNR d'Innovation, Sciences et Développement économique Canada applicables aux appareils radio exempts de licence. L'exploitation est autorisée aux deux conditions suivantes:

- (1) L'appareil ne doit pas produire de brouillage;
- (2) L'appareil doit accepter tout brouillage radioélectrique subi, même si le brouillage est susceptible d'en compromettre le fonctionnement.

To maintain compliance with RSS's RF Exposure guidelines, this equipment should be installed and operated with minimum distance between 20cm the radiator your body: Use only the supplied antenna.

Pour rester conforme aux directives d'exposition aux radiofréquences de RSS, cet équipement doit être installé et utilisé à une distance minimale de 20cm du radiateur de votre corps : Utilisez uniquement l'antenne fournie.

8.1.4 EU (CE)

This product complies with the following regulation tests.

ETSI EN300 328 V2.2.2

EN 62479: 2010

8.2 Bluetooth® Qualification

QDID: 232479

Product Type: Component (Tested)

9 Precautions

- The contents of this document, including information on hardware, software, and systems (hereinafter referred to as "Products"), are subject to change without notice due to technological progress or other reasons.
- Reproduction or reprinting of this material without our written consent is prohibited. Even if you reproduce or reprint this material with our written consent, please do not change or delete any of the contents.
- Although we strive to improve the quality and reliability of our products, semiconductor and memory devices may be subject to malfunctions or failures. When using this product, it is the customer's responsibility to ensure that the customer's hardware, software, and systems have the necessary safety design in place to prevent infringement of life, limb, or property due to malfunction or failure of this product. When designing and using this product, please confirm and follow the latest information on this product (this document, specifications, data sheets, application notes, etc.) as well as the instruction manuals and operating manuals of the equipment in which this product is used. In addition, when using information such as product data, diagrams, tables, and other technical content, programs, algorithms, and other application circuit examples shown in the above materials, etc., please fully evaluate your product alone and as a whole system, and determine its applicability under your own responsibility.
- This product is not intended or warranted for use in the following equipment (hereinafter referred to as "specific applications"):
 - equipment that requires a particularly high level of quality and reliability.
 - equipment whose malfunction could endanger life or body, cause extensive property damage, or have a serious impact on society.Specific applications include nuclear power-related equipment, aerospace equipment, medical equipment, automotive and transportation equipment, train and ship equipment, traffic signal equipment, combustion and explosion control equipment, various safety-related equipment, elevating equipment, electric power equipment, and financial-related equipment, but exclude applications that are individually described in this document. We assume no responsibility for any specific use of the product.
- Do not disassemble, analyze, reverse engineer, or duplicate to this product.
- Do not use this product for any product whose manufacture, use, or sale is prohibited by domestic or foreign laws, regulations, or orders.
- The technical information contained in this document is intended to explain the typical operation and application of the product, and its use does not constitute a guarantee or license to any intellectual property rights or other rights of our company or any third party.
- Unless otherwise agreed to in a separate written contract or specification agreed between you and us, we make no warranties of any kind (including, but not limited to, the warranties of functionality, merchantability, fitness for a particular purpose, accuracy of information, and non-infringement of third party rights), either express or implied, with respect to this product and technical information.
- Do not use this product or the technical information contained in this document for the purpose of developing weapons of mass destruction, for military use, or for any other military purpose. When exporting, please comply with applicable export laws and regulations such as "Foreign Exchange and Foreign Trade Law" of Japan and "U.S. Export Administration Regulations" and follow the necessary procedures as prescribed by those laws and regulations.